

MNT-110-W

Wall Mount Bracket



Features

- Material: Aluminum
- Wall Mount/Plane Mount/Ceiling Mount
- Bracket Neat & Integrated design

Specifications

Model	MNT-110-W
General	
Material	Aluminum
Dimension (W x H x D)	φ95mm x 195mm
Pipe Thread	1/4"-20 UNC
Operating Temperature	-40°C~60°C
Humidity	0~90% RH
Load Bearing	1.0Kg
Weight	0.18Kg
Color	White

Dimensions (mm)

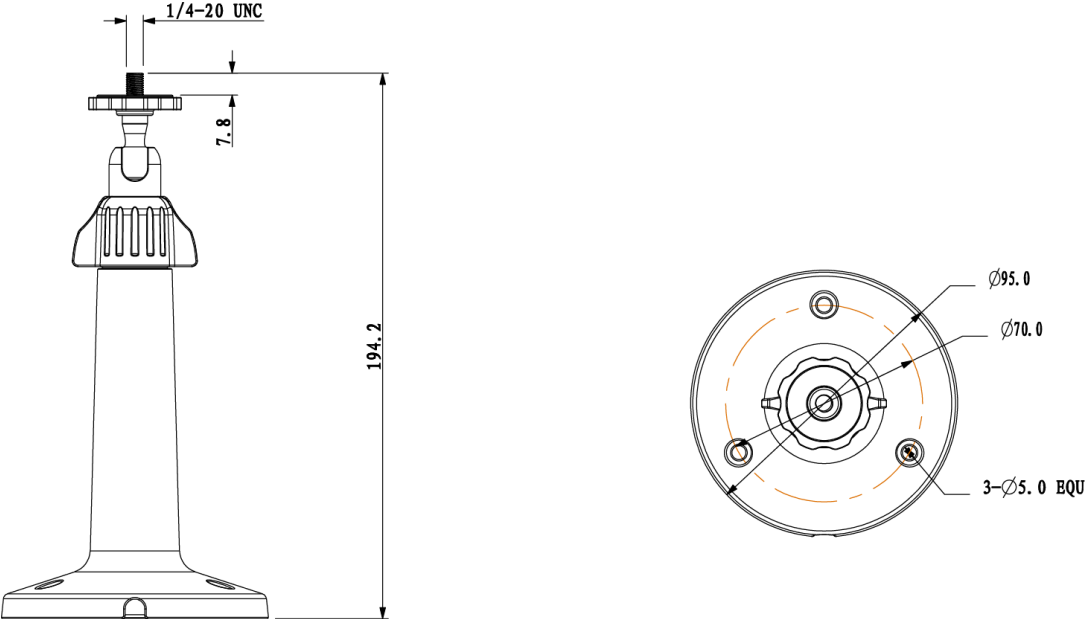

Application

