

MNT-200C

SPECIFICATIONS

Material	Aluminium
Dimension (W x D x H)	Ø166.0x75.8mm
Pipe Thread	G3/4"
Operating Temperature	-40°C -60°C
Humidity	0-90% RH
Load Bearing	1.0Kg
Weight	0.32kg
Colour	White
Compatible With	Refer to relevant camera(s) sales documents

FEATURES

Material	SECC & PC
Type	In-Ceiling Mount Bracket
Design	Neat & Integrated



DIMENSIONS & APPLICATION

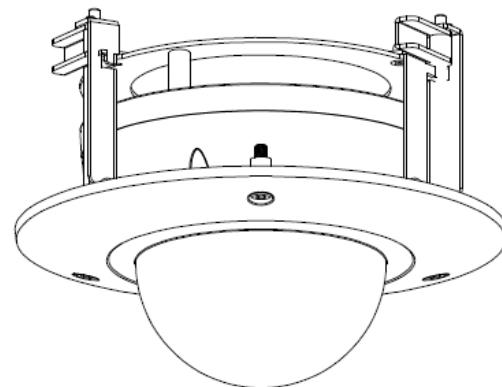
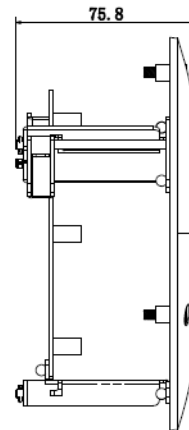
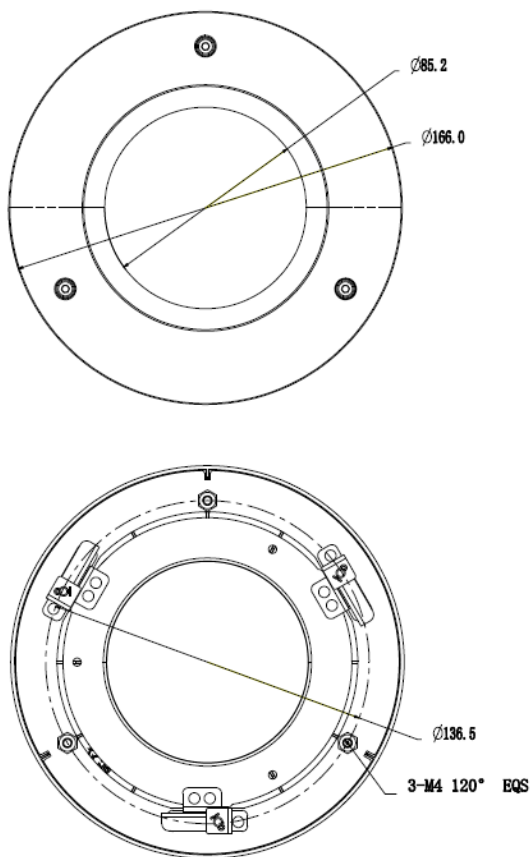

Email us info@icrealtime.net or visit www.icrealtime.net

• **European Head Office**
• IC Realtime,
• 12 Knockmitten Lane,
• Western Industrial Estate,
• Dublin 12,
• Ireland

• **UK Office**
• IC Realtime UK
• Surrey Technology Centre,
• 40 Occam Road,
• Guildford GU2 7YG,
• United Kingdom

• **USA Head Office**
• IC Realtime, LLC,
• 3050 N Andrews Ave EXT,
• Pompano Beach,
• FL 33064,
• USA

• **USA West Coast Office**
• IC Realtime West Coast,
• 14180 W Van Buren Street,
• Suite B-105, Goodyear,
• AZ 85338,
• USA