

MNT-300W

Wall Mount Bracket



Features

- Material: Aluminum
- Wall Mount Bracket
- Neat & Integrated design

Specifications

Model	MNT-300W
General	
Material	Aluminum
Dimension (W x H x D)	210mm(W) x 115mm(H) x 160mm(D)
Pipe Thread	1 1/2" PF
Operating Temperature	-40°C ~60°C
Humidity	0~90% RH
Load Bearing	7.0Kg
Weight	0.5kg
Applicable Model	PFA100, PFA101, PFA102, PFA110, PFA111, PFA114

MNT-300W

Dimensions (mm)

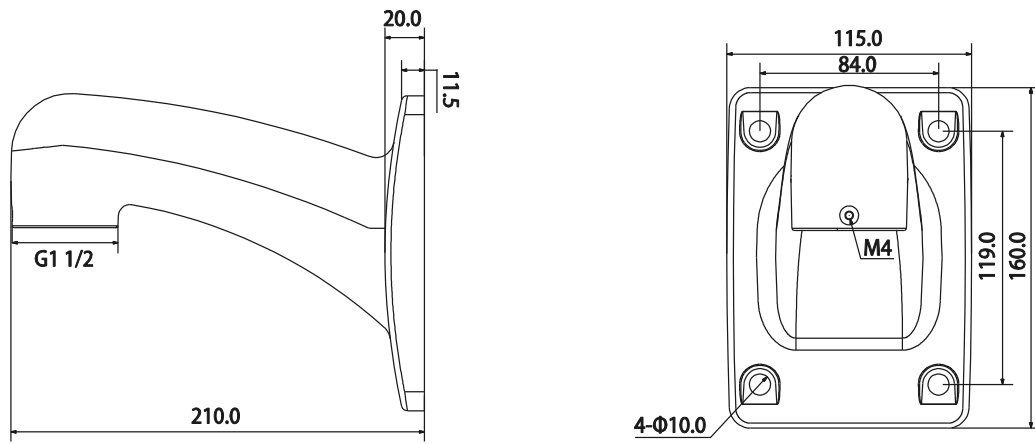

Application

