

# MNT-310-W

## Integration Bracket of PTZ Camera



### Features

- Neat & Integrated design, wall-mount.
- Material: Aluminum.
- Come with a junction box at the bottom of the bracket, there are two out-holes (G3/4) designed at the bottom, which is convenient for cable hiding and wiring.
- Safety rope hook attached, secure and reliable.
- Snap-in type, easy installation by snap locking the two parts together.
- Its Load Bearing is 8.0kg, compatible with most of our PTZ cameras.

### Technical Specifications

<b>Model</b>	MNT-310-W
<b>General</b>	
Material	Aluminum
Dimension (W x H x D)	363mm x 174mm x 135mm(14.29" x 6.85" x 5.31")
Weight	2.0kg(4.41lb)
Load Bearing	8.0kg(17.64lb)
Color	White
Operating Temperature	-40°C ~60°C(-40°F ~140°F)
Humidity	0~90% RH

### Dimensions (mm/inch)

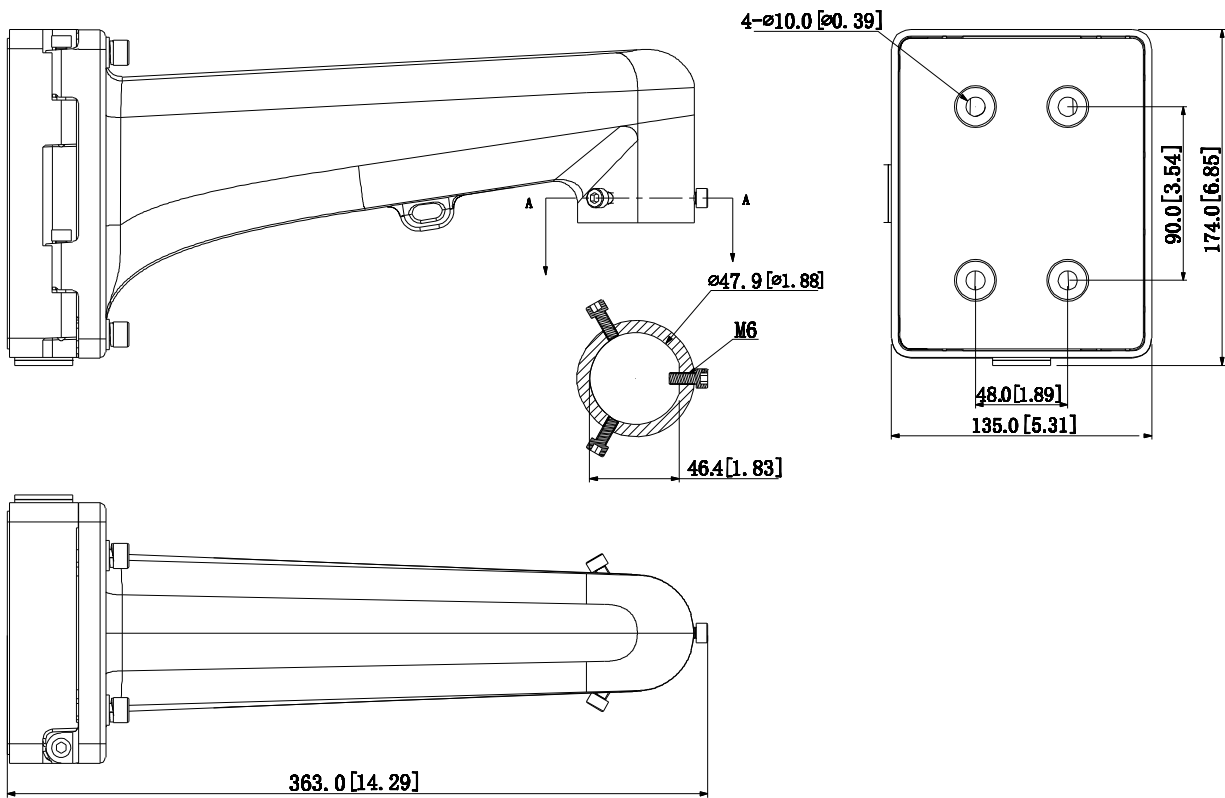

### Application



### Package Information

- Integration Bracket \*1
- Application manual \*1
- Wrench \*2

Package data	
Box Dimension	393mm x 212mm x 180mm (15.47" x 8.35" x 7.09")
Box Weight	2.5kg (5.51lb)
Protective Box Dimension	662mm x 412mm x 393mm (26.06" x 16.22" x 15.47")
Box In Protective Box	6 In 1