



EXTERNAL MAGNETIC LOCK (1200LB)

MAGNETIC LOCK

IP66 external range of maglocks and brackets from a market leader in access control.



**EXML1200-GATE &
EXML1200-GATE-M**

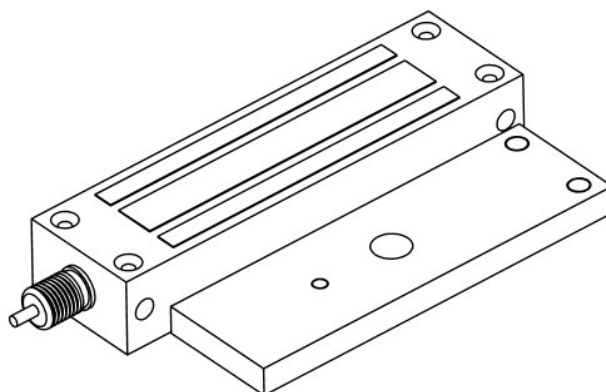
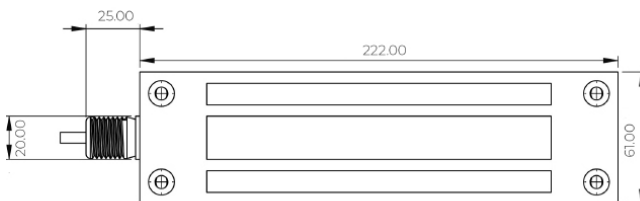

SPECIFICATION

- EXML1200-GATE & EXML1200-GATE-M
- Stainless steel housing
 - 545kg (1200lb) holding force
 - Dual voltage 12/24 VDC @ 500/250mA
 - Comes complete with 1 metre cable
 - Built in surge protection
 - Surface mount
 - Fail safe operation (power to lock)
 - +/- 15% voltage tolerance
 - -10° to +50° operating temperature
 - Push off release pin on armature
 - COM/NO/NC Voltage free relay contacts

- EXML1200-GATE-M
- Monitored

FEATURES

- EXML1200-GATE & EXML1200-GATE-M
- External magnet IP66
 - Weatherproof
 - Dual voltage 12V/24V
 - Side or face fixing
 - Armature comes with fixing kit

- Suitable Brackets/Housings:
- BKEX1200ZL (ZL bracket)
 - BKEX1200L (L bracket)

OTHER PRODUCTS

WP66-G-GB-GR



KPX50



RAINSHIELD



TRAN01-REC01



DIMENSIONS

- EXML1200-GATE & EXML1200-GATE-M
- 222x61x38 (mm) Maglock
 - 195x60x14 (mm) Armature
 - 4.5kg Boxed
 - 2.85kg Unboxed

CONTENTS

- EXML1200-GATE & EXML1200-GATE-M
- External magnet
 - Armature plate
 - EX1200GB fixing kit
 - Instructions
 - Armature fixing template

