

Satel®

abax2

ACMD-200

Wireless carbon monoxide detector

CE

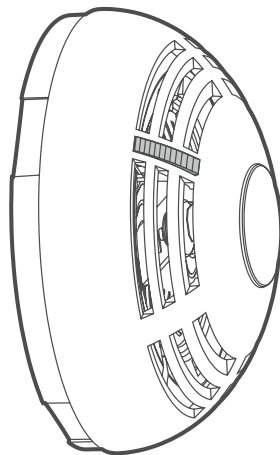

Firmware version 1.00

EN
acmd-200_en 10/21

SATEL sp. z o.o. • ul. Budowlanych 66 • 80-298 Gdańsk • POLAND
tel. +48 58 320 94 00
www.satel.eu

IMPORTANT

Prior to installation, please read carefully this manual in order to avoid mistakes that can lead to malfunction or even damage to the equipment.

Changes, modifications or repairs not authorized by the manufacturer shall void your rights under the warranty.

The rating plate of the device is located inside the enclosure.



The device meets the requirements of the applicable EU directives.



The device is designed for indoor installation.



The device must not be disposed of with other municipal waste. It should be disposed of in accordance with the existing rules for environment protection (the device was placed on the market after 13 August 2005).



The device meets the technical regulations of the Eurasian Customs Union.

SATEL aims to continually improve the quality of its products, which may result in changes in their technical specifications and software. Current information about the changes being introduced is available on our website.

Please visit us at:

<https://support.satel.eu>

Hereby, SATEL sp. z o.o. declares that the radio equipment type ACMD-200 is in compliance with Directive 2014/53/EU. The full text of the EU declaration of conformity is available at the following internet address: www.satel.eu/ce

In the EU, this radio equipment is only permitted to operate in the 868 MHz frequency band.

The following symbols may be used in this manual:



- note,



- caution.

CONTENTS

1. Features	2
2. Description.....	2
3. Selecting a mounting location.....	4
4. Installation	4
5. Battery replacement	5
6. Specifications	7

The ACMD-200 detector detects carbon monoxide. It is designed to work as a stand-alone device or within the ABAX 2 two-way wireless system. The detector is supported by:

- ACU-220 / ACU-280 controller (firmware version 6.03 or newer),
- ARU-200 repeater.

1. Features

- Electrochemical carbon monoxide sensor.
- Digital temperature compensation.
- Test feature.
- LED for optical signaling.
- Built-in sounder.
- Supervision of gas sensor.
- Battery status control.
- Operation within the ABAX 2 wireless system:
 - encrypted two-way radio communication in the 868 MHz / 915 MHz frequency band (AES standard),
 - transmission channel diversity – 4 channels for automatic selection of the one that will enable transmission without interference with other signals in the 868 MHz / 915 MHz frequency band,
 - “ECO” option for longer battery life,
 - support for built-in temperature sensor (temperature measurement range from 0°C to +55°C).
 - tamper protection against enclosure opening.

2. Description

Alarm

The detector reports alarm when it detects a dangerous gas concentration. Gas concentration to trigger alarm:

- 50-75 ppm for 75 minutes,
- 75-120 ppm for 25 minutes,
- higher than 120 ppm for 1 minute.

The alarm is signaled by the red LED light and a beep sound emitted continuously for 5 minutes. If the detector continues to detect a dangerous gas concentration after that time, this will be signaled by two short LED flashes and two short beeps every 2 seconds. The detector will stop reporting the alarm when the gas concentration drops below a dangerous level.



The gas sensor reaction to a decrease in the dangerous gas concentration is delayed, hence the restore of alarm can take place even a few minutes after the gas concentration has dropped below the alarm level.

Pressing the test / reset button (Fig. 1) during the alarm will clear the alarm condition. When a dangerous gas concentration is detected again, the alarm will reactivate.

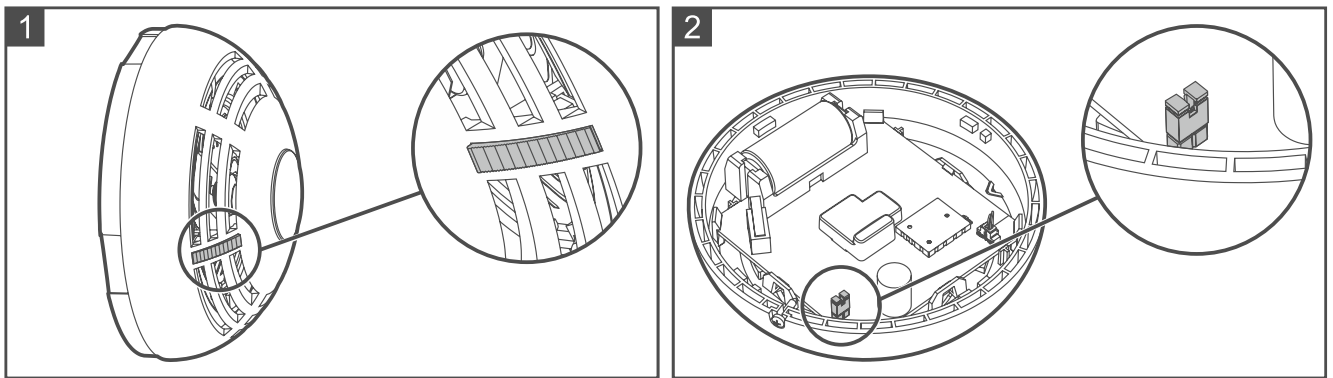

Operating modes

You can set the operating mode using the jumper located on the electronics board (Fig. 2):

- jumper off – stand-alone mode,
- jumper on – working in the ABAX 2 system. The detector is operating similarly as in the stand-alone mode, but it additionally:
 - communicates with the ABAX 2 controller,
 - supervises the tamper switch state.



Set the operating mode when no battery is installed in the detector.

Detector test

If you want to test operation of the detector, press the test / reset button (Fig. 1). You will hear a short beep. Wait a few seconds until an alarm is triggered.

LED

LED indicates:

- low battery – 3 short flashes every 30 seconds,
- gas sensor trouble – 4 short flashes every 30 seconds,
- alarm – ON for 5 minutes. After that time, the alarm will be signaled by two short LED flashes every 2 seconds.

In the ABAX 2 system, after the test mode is started, the LED also indicates periodical communication – short flash (80 milliseconds).

Sounder

Sounder indicates:

- low battery – 3 short beeps every 30 seconds,
- gas sensor trouble – 4 short beeps every 30 seconds,
- alarm – continuous beep sound for 5 minutes. After that time, the alarm will be signaled by two short beeps every 2 seconds.

Supervision of gas sensor

In the event of sensor failure (e.g. end of life), the gas sensor trouble will be indicated by the LED and sounder.



The gas sensor life is up to 10 years.

Battery status control

When the battery voltage is lower than 2.75 V, the low battery is indicated by the LED and sounder. If the detector is working in the ABAX 2 system, information about low battery is sent during each transmission to the controller.

Working in the ABAX 2 system

Radio communication

The detector connects to the controller at regular time intervals to provide information about its state (periodical communication). Additional communication takes place in the case of alarm (carbon monoxide is detected) or tamper (tamper switch has been opened) and after restore of alarm (carbon monoxide is no longer detected) or tamper (tamper switch has been closed).

Test mode

Diagnostics of the detector is easier in the test mode in which the detector LED indicates periodical communication. For how to start and end the test mode, refer to the ABAX 2 controller manual.

Energy saving mode (ECO)

If you want to prolong the battery life, you can enable in the detector the “ECO” option. When the “ECO” option is enabled, the periodical communication takes place every 3 minutes. This can increase the battery life by as much as four times.

3. Selecting a mounting location

- The detector is designed for indoor operation.
- Suggested locations for mounting the detector:
 - bedroom,
 - room with a fireplace / combustion equipment, where there is a risk that carbon monoxide is produced.
- Install the detector at a height of about 1.5-2 meters from the ground.
- Do not install the detector in places where lacquers, glues, paint removers or aerosols are used. It may have a negative impact on the gas sensor operation.
- If the detector is to work in the ABAX 2 system, installing the device in close vicinity of electrical systems is not recommended, since it can adversely affect the range of radio signal.

4. Installation



The detector enclosure cannot be closed without the battery inserted.

Do not install the battery if the sounder is disconnected.

There is a danger of battery explosion when using a different battery than recommended by the manufacturer, or handling the battery improperly. Do not crush the battery, cut it or expose it to high temperatures (throw it into the fire, put it in the oven, etc.).

Do not expose the battery to very low pressure due to the risk of battery explosion or leakage of flammable liquid or gas.

Be particularly careful during installation and replacement of the battery. The manufacturer is not liable for the consequences of incorrect installation of the battery.

1. Remove the detector cover (Fig. 5).
2. If the detector is to work as a stand-alone device, remove the jumper (Fig. 2) and skip the steps 5-9.



After the battery is installed, removing / placing the jumper will have no effect on the detector operation.

3. Install the battery (Fig. 7).
4. Add the detector to the wireless system (see the ABAX 2 controller manual). The sticker with the serial number required to register the detector in the system can be found on the electronics module.
5. Replace the cover.
6. Put the detector at the place of its future installation.
7. Check the level of signal received from the detector by the ABAX 2 controller. If the signal level is lower than 40%, select another place for installation. Sometimes, it is sufficient to shift the device ten or twenty centimeters. You can also try to turn the enclosure to check what effect the change of antenna position will have on the signal strength.



The ARF-200 tester allows you to test the level of radio signal at the location of future installation without having to place the detector on-site.

8. Remove the detector cover.
9. Secure the enclosure base to the wall or ceiling with wall plugs (screw anchors) and screws. The wall plugs (anchors) delivered with the detector are intended for concrete, brick, etc. For other types of surface (drywall, styrofoam), use the appropriately selected wall plugs.
10. Replace the cover (Fig. 8), turn it clockwise (Fig. 9) and lock it using the screw (Fig. 10).
11. Press the test / reset button (Fig. 1). An alarm should be triggered.



The detector is tested during production process with special gas mixtures. It is forbidden to test the detector by any improvised methods.

5. Battery replacement



The used batteries must not be discarded, but should be disposed of in accordance with the existing rules for environment protection.

Replace the battery when the detector indicates low battery (3 short LED flashes and 3 short beeps every 30 seconds).

1. Start the service mode in the control panel (if the detector is working in the ABAX 2 system and the controller is connected to a SATEL alarm control panel).
2. Remove the screw fastening the cover (Fig. 3).
3. Turn the cover counter-clockwise (Fig. 4) and remove it (Fig. 5).

- 4. Remove the discharged battery (Fig. 6).
- 5. Install a new CR123A 3 V lithium battery (Fig. 7).
- 6. Replace the cover (Fig. 8).
- 7. Turn the cover clockwise (Fig. 9).
- 8. Lock the cover using the screw (Fig. 10).
- 9. Press the test / reset button (Fig. 1). An alarm should be triggered.

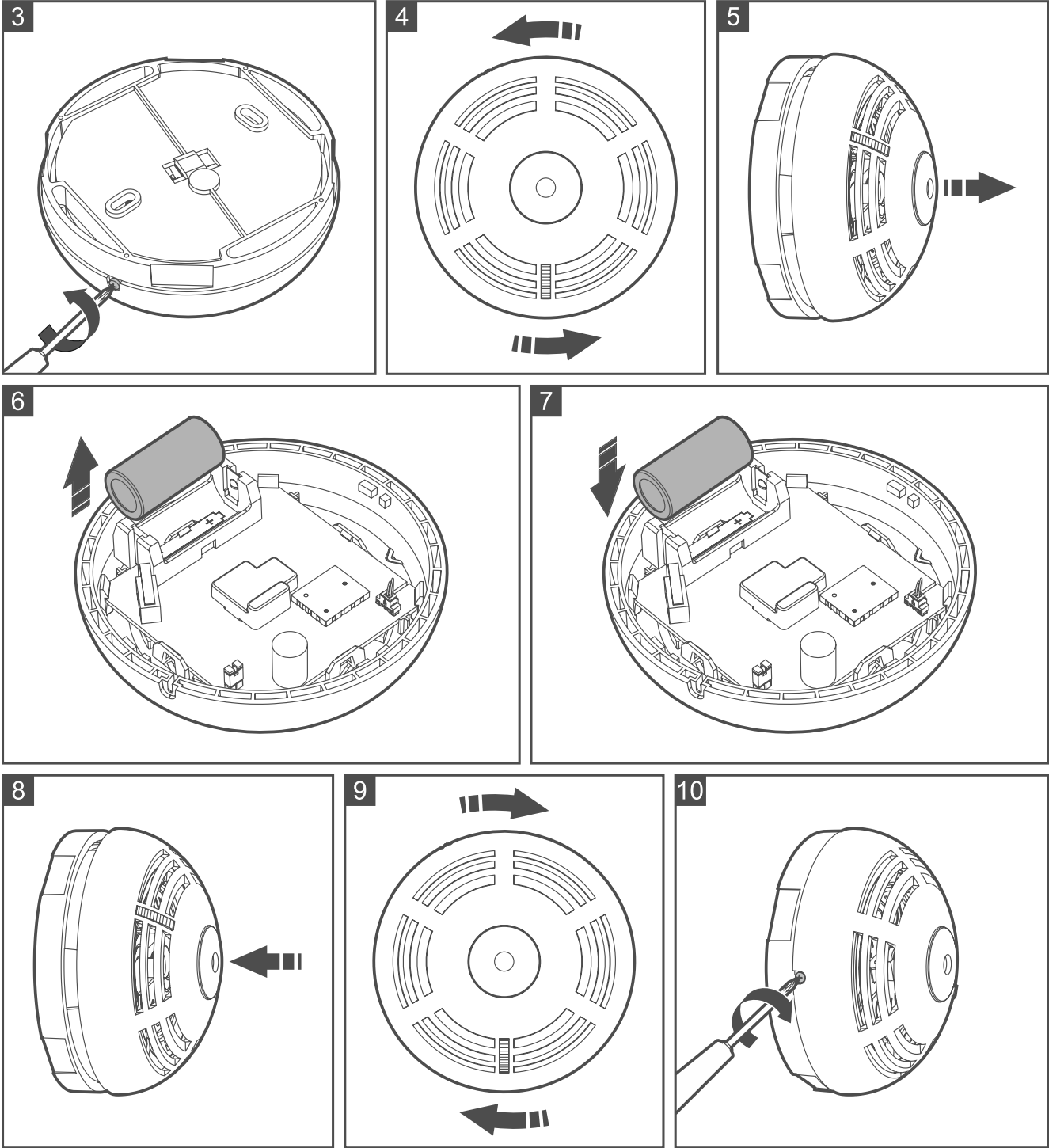

6. Specifications

Operating frequency band	868.0 MHz ÷ 868.6 MHz / 915 MHz – 928 MHz
Radio communication range (in open area)	
ACU-220.....	up to 2000 m
ACU-280.....	up to 1200 m
Battery	CR123A 3 V
Battery life expectancy	
ABAX 2	up to 2 years
stand-alone mode	up to 5 years
Standby current consumption	
ABAX 2	62 µA
stand-alone mode	14 µA
Maximum current consumption	120 mA
Operating temperature range.....	0°C...55°C
Maximum humidity	93±3%
Dimensions	ø108 x 49 mm
Weight.....	151 g